

Model 05

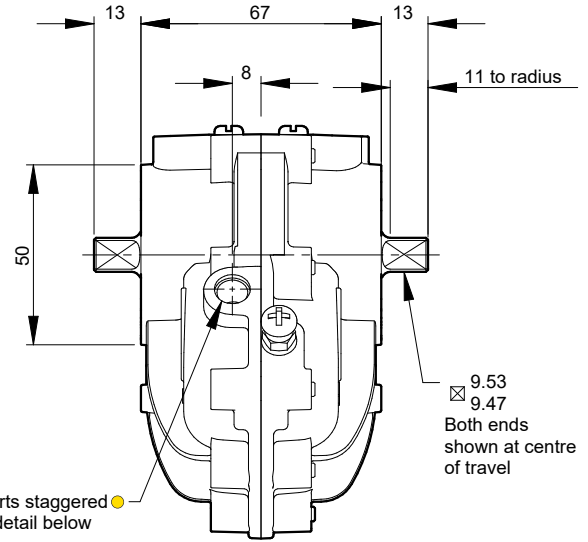

Standard Coupling
(supplied with actuator
weight 0.09 lbs/0.04 kg)

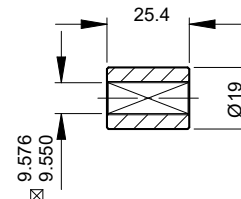

Specification

Output Torque

440 lbf ins/50.5 Nm
at 100 psi/7 bar

Angle of Travel (adjustable)

84° - 100°
(restricted travel
versions available)

Displaced Volume

6.9 in³/113 cm³

Finish

Epoxy stove enamel

Weight

2.73 lb/1.24 kg
(excluding coupling)

For further information
see General Specification
on page 5.

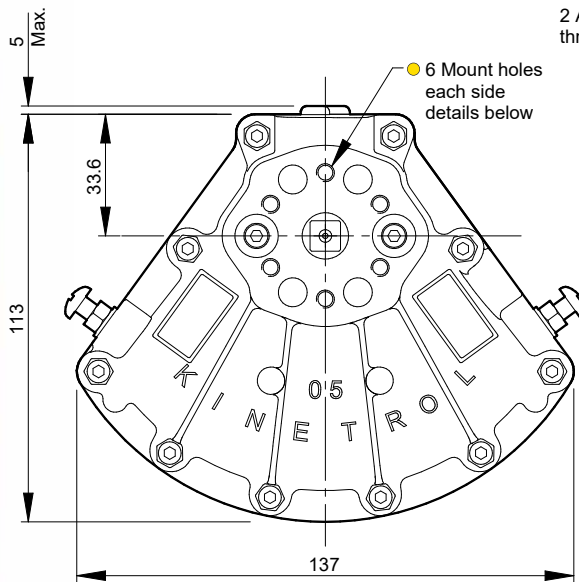

Air Port/Mount Hole Details

Model	Air Ports	Mount Holes
054-100	G ¹ / ₈	6 x M5 x 10 deep on 34.9 PCD
057-100	1/ ₈ NPT	6 x 10-24 UNC x 0.39" deep on 1.375" PCD

Visual Red Indicator supplied as standard - see page 3

Options

- Fail safe spring return units - clockwise or counter clockwise see pages 27-29
- Limit switch boxes for open/close indication - various switches for hazardous areas see pages 31-34
- Integral solenoid valve see page 38
- AP pneumatic positioner - full range of options see pages 41/42
- EL electropneumatic positioner - full range of options see pages 39/40
- P3 on/off positioner- full range of options including hazardous area see pages 43-45
- Clear Cone position monitor see page 38
- 180° model see pages 51/52
- Female drive and mounting details to DIN 3337 and ISO 5211 see pages 57/58
- ISO adaptor see page 26
- Spring to centre see page 50
- Geared manual override see page 55
- Code identification see page 30
- Torque outputs see pages 6-8
- See pages 57-60 for English dimensions and dimensions of spring options
- High temperature / Low temperature options see page 5

